

CIRCULAR VIBRATOR MOD. VBC-S 150/400/600

VIBRATORE CIRCOLARE



FINISHING SYSTEMS

IT EN DE FR

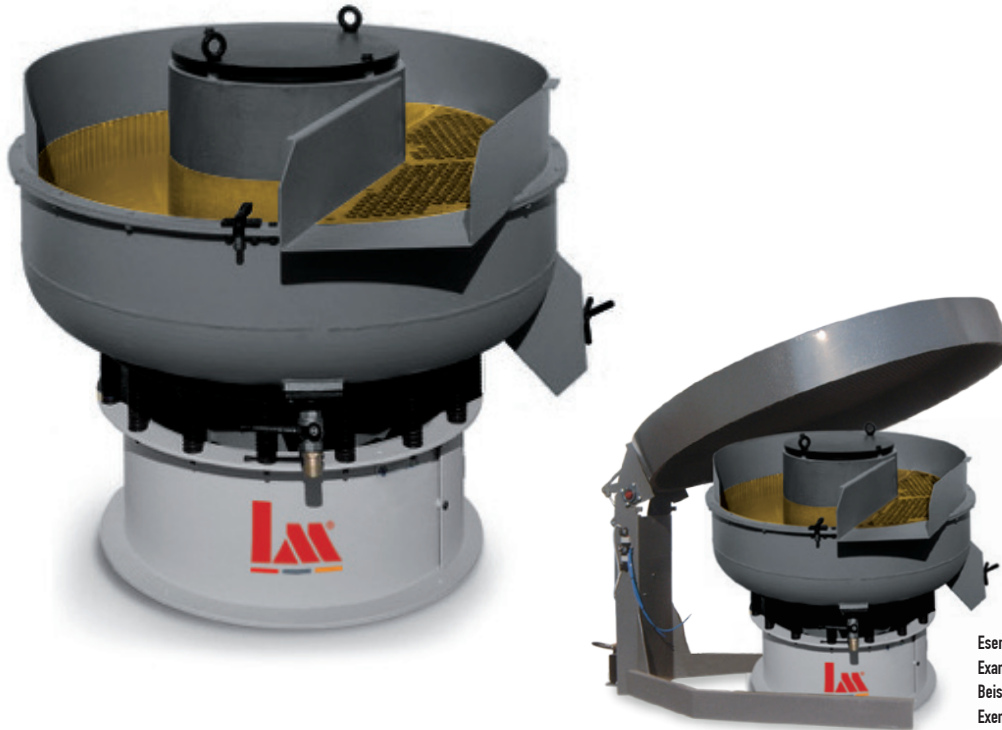

Esempio di quadro elettrico touch screen.
Example of touch screen electrical panel.
Beispiel eines Schaltschranks mit Touchscreen.
Exemple de tableau électrique écran tactile.

Esempio di vibratore circolare con coperchio insonorizzato.
Example of circular vibrator with soundproof cover.
Beispiel eines Kreisförmigen Rüttlers mit Schallschutzhaube.
Exemple de vibreur circulaire avec couvercle insonorisé.

TECHNICAL DETAILS

MODEL	150	400	600
A mm	1050	1250	1380
B mm	800	965	1060
C mm	980	1285	1530
D mm	260	345	440
E mm	1150	1450	1680
F mm	290	370	430
CAPACITY	140 L	330 L	550 L
R.P.M.	1500	1500	1500
MOTOR	2.15 kW	4 kW	7 kW
WEIGHT	650 kg	900 kg	1200 kg

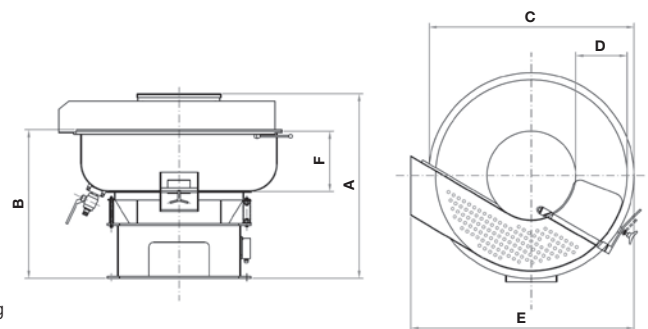

Vibratori circolari adatti al settore industriale, con vasca rivestita in poliuretano antiabrasivo, scarico automatico dei pezzi. Griglia setaccio intercambiabile.

Optional:

- ▶ Variatore di velocità elettronico
- ▶ Coperchio pneumatico insonorizzato
- ▶ Pompa dosatrice
- ▶ Touch screen

Circular vibrators for the industrial sector, with anti-abrasive polyurethane coated tank, automatic unloading of parts. Interchangeable sieve grid.

Optional:

- ▶ Electronic speed variator
- ▶ Soundproof pneumatic cover
- ▶ Dosing pump
- ▶ Touch screen

Kreisförmige Rüttler für den Industriebereich, mit Wanne mit scheuerbeständiger Polyurethan-Beschichtung und automatischem Stückeauslass. Auswechselbares Netzsieb.

Optional:

- ▶ Elektronischer Drehzahlregler
- ▶ Pneumatische Schallschutzhaube
- ▶ Dosierpumpe
- ▶ Touchscreen

Vibrateurs circulaires adaptés au secteur industriel, avec cuve revêtue en polyuréthane résistant à l'abrasion, déchargement automatique des pièces. Grille tamis interchangeable.

En option:

- ▶ Variateur de vitesse électronique
- ▶ Couvercle pneumatique insonorisé
- ▶ Pompe doseuse
- ▶ Écran tactile